

Body Control Module (BCM) X1

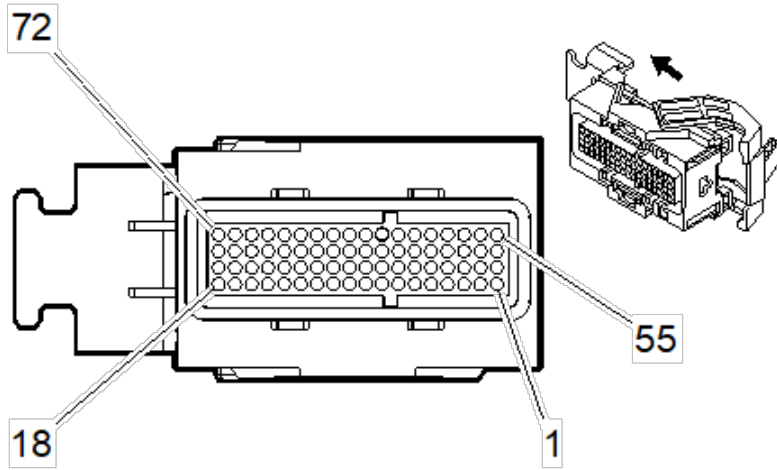

Connector Part Information

- Harness: Body
- OEM: 15393122
- Service: 88987847
- Description: 72-Way F Micro 64 (GY with BU cover)

Terminal Part Information

- Terminal/Tray: 15359541/4
- Core/Insulation Crimp: M/M
- Release Tool/Test Probe: 15381651-2/J-35616-64B (L-BU)

Body Control Module (BCM) X1

Pin	Wire	Circuit	Function
1	0.35 L-BU/BK	747	Left Rear Door Ajar Switch Signal (Sedan)
2	—	—	Not Used
3	0.35 PU	5531	Hood Closed Switch Signal (AP3)
4	0.35 PK/BK	109	Hood Ajar Switch Signal (AP3)
5	—	—	Not Used
6	0.35 WH	682	Door Lock Lock/Unlock Signal (AU3)

Pin	Wire	Circuit	Function
7	0.35 WH	682	Door Lock Lock/Unlock Signal (AU3)
8	0.35 WH	1080	Park Lamp Relay Control
9-12	—	—	Not Used
13	0.35 PK	849	Brake Fluid Level Sensor Signal
14	0.35 L-BU	1134	Park Brake Switch Signal
15	0.35 YE	5199	Run/Crank Relay Coil Control
16	0.35 WH	193	Rear Defog Relay Control
17	0.5 D-BU	15	Right Front Turn Signal Lamp Supply Voltage
18	0.35 D-GN	5060	Low Speed GMLAN Serial Data
19	0.35 TN/WH	746	Right Front Door Ajar Switch Signal
20	0.35 L-GN/BK	748	Right Rear Door Ajar Switch Signal (Sedan)
21	—	—	Not Used
22	0.35 GY/BK	745	Left Front Door Ajar Switch Signal
23-25	—	—	Not Used
26	0.35 L-GN	1478	Coolant Level Switch Signal (LNF)
27-30	—	—	Not Used
31	0.35 WH	5065	CHMSL Relay Coil Supply Voltage
32	—	—	Not Used
33	0.35 D-GN/WH	1135	A/T Shift Lock Control Solenoid Supply Voltage (MN5)
34	—	—	Not Used
35	0.35 L-BU	14	Left Front Turn Signal Lamp Supply Voltage
36	0.35 D-GN	5060	Low Speed GMLAN Serial Data (UE1)
37-39	—	—	Not Used
40	0.35 L-BU	1788	Traction Control Switch Signal (JL4 or JL9)
41-43	—	—	Not Used
44	0.35 TN/WH	1969	Headlamp High Beam Relay Control

© 2019 General Motors. All rights reserved.

Pin	Wire	Circuit	Function
45-46	—	—	Not Used
47	0.5 YE	196	Windshield Wiper Motor Park Switch Signal
48-50	—	—	Not Used
51	0.35 D-GN	113	Windshield Wiper Switch Signal
52-53	—	—	Not Used
54	0.35 YE	317	Fog Lamp Relay Control (T37)
55	0.35 OG/BK	744	Rear Compartment Lid Ajar Switch Signal
56	—	—	Not Used
57	0.35 BN	253	Trunk Release Relay Control
58-59	—	—	Not Used
60	0.35 TN	28	Horn Relay Control
61	0.5 BK	1250	Ground
62	0.35 RD/WH	1240	Battery Positive Voltage (LAP)
63	0.35 GY	596	5-Volt Reference 1 (LAP)
64	0.5 BK	650	Ground (LAP)
65-66	—	—	Not Used
67	0.35 YE/BK	61	Low Reference
68	0.35 WH	5075	Current Sensor Signal (LAP)
69	—	—	Not Used
70	0.35 D-GN/WH	636	Ambient Air Temperature Sensor Signal
71	0.35 L-GN/BK	592	DRL Relay Control
72	—	—	Not Used